

DIVISION OF CEMETERIES

STATE OF NEW YORK
DEPARTMENT OF STATE

STATE OFFICE BUILDING
44 HAWLEY STREET
BINGHAMTON, NY 13901
TELEPHONE: (607) 721-8756
FAX: (607) 721-8753
WWW.DOS.NY.GOV

ANDREW M. CUOMO
GOVERNOR

CEMETERY BOARD

ROSSANA ROSADO
SECRETARY OF STATE
CHAIR

LETITIA JAMES
ATTORNEY GENERAL

DR. HOWARD A. ZUCKER
COMMISSIONER OF HEALTH

TO: New York State Cemetery Board

FROM: Brendon Stanton, Investigator

SUBJECT: Riverhurst Memorial Association, #04-027

RE: Application for Approval of a Columbarium

DATE: February 16, 2021

Exhibits

- A) Report of Senior Accountant Andrew Hickey
- B) Application from Riverhurst Memorial Association
- C) Board minutes approving the columbarium project
- D) Map of the project area
- E) Sketch of the proposed columbarium unit
- F) Photograph of the sign required by 19 NYCRR Section 201.11

Introduction and Recommendation

The Riverhurst Memorial Association of the town of Union, Broome County, has applied for Cemetery Board approval for the installation of a 96-niche columbarium unit. The cemetery currently has five traditional full-body mausoleum units and one columbarium unit. This installation is the second columbarium unit of a planned five-unit installation.

I recommend approval of this application.

The Columbarium

The Riverhurst Memorial Association proposes to purchase a pre-built 96-niche columbarium unit and install it in the cemetery. This columbarium unit will be adjacent to an existing mausoleum, referred to by the association as Mausoleum 3, as well as another columbarium unit that was previously installed in 2019. The association plans to install three additional columbarium units in this area at a later date.

The columbarium unit is constructed by Premier Columbaria of Tacoma, WA. It will arrive on site in a preassembled or mostly assembled condition. The concrete foundation for this unit has already been poured. It is constructed of granite, with sixteen columns of six



**Department
of State**

companion niches each arranged in a circular fashion, for a total of 96 niches comprised of 192 inurnment spaces. There is a concrete walkway leading up to the area which was installed with the previous columbarium unit.

Compliance with 19 NYCRR Section 201.11

The cemetery has demonstrated compliance with 19 NYCRR Section 201.11. Specifically:

1. Whether the proposed construction has the approval of the corporation's lot owners, obtained at a special or regular meeting. If not, a description of the authorization or approval obtained. The cemetery's board of directors met on September 20, 2018, and approved the construction of the columbarium. A copy of the meeting minutes is attached (Exhibit C).

2. (A) The name of the licensed architect or engineer and the estimated total costs of construction, including land to be appropriated, landscaping, embellishments and other features. This unit is preassembled by Premier Columbaria of Tacoma, WA. The estimated total cost of construction is \$17,684.00.

(B) A map or sketch indicating the location of the building, together with a general description including the number of crypts and niches. The described map and sketch are attached (Exhibits D and E).

(C) Whether the proposed construction is the complete structure or whether units are to be added later. If future units are contemplated, the extent of such commitment or plan. This is designed as phase two of a five-phase columbarium area. There are no commitments to additional structures at this time. Rather, it is dependent on whether the existing units are successful.

3. The source of funds to pay for the construction and the terms of payment. The cemetery will use general funds for the entirety of the project. The cemetery has indicated that it will be funded primarily from donations received specifically for the installation of an additional columbarium unit.

4. An estimate of the trust funds and the current maintenance funds required to maintain and preserve the facility, covering the year-to-year maintenance and long-term preservation. See attached report of Senior Accountant Andrew Hickey (Exhibit A) for further financial analysis.

5. An estimate of the cumulative total revenues from sales based on the projected selling prices. See attached report of Senior Accountant Andrew Hickey (Exhibit A) for further financial analysis.

6. A full disclosure to the extent outstanding certificates of indebtedness or land shares are to participate in the sales proceeds. The cemetery has no outstanding certificates of indebtedness or land shares.

7. The projected disposition of the total estimated sales revenues, including but not limited to the amounts to be allocated for: (A) permanent maintenance and current maintenance funds; (B) supplemental trust or special fund; (C) estimated selling expenses, including disclosure of promotional plans; (D) recovery of construction costs;

(E) general fund use or retention; and (F) building operation. See attached report of Senior Accountant Andrew Hickey (Exhibit A) for further financial analysis.

8. (A) A copy of the drawing required by paragraph (B) of this subdivision along with an indication of the location of the proposed building, and a statement that the notices required by such paragraph have been posted in accordance with its provisions. The cemetery has posted the required notice and a copy of that sign is attached (Exhibit F).

Issues with Notice

The cemetery informed me that it had posted the required notices at the entrance and the construction site on December 1, 2020. I visited the site to verify these postings on December 29, 2020, and was unable to locate the sign at the main entrance. When I questioned the staff, they indicated that it must have fallen down as a result of a snowstorm that occurred on December 16-17, 2020. The cemetery notified me that the sign had been replaced on December 29, 2020. However, the staff observed that it was missing again on January 3, 2021, and asked if it could be moved to a different location. I responded that a posting by the entrance is required, and they replaced it on January 5, 2021. I verified that it was posted on January 8, 2021, and to the best of my knowledge it remains posted today. This application was originally prepared for the February meeting of the Cemetery Board; since it will now be presented at the March meeting, there remains no issue since the entire 60 day comment period will have elapsed before the meeting.

Recommendation

The cemetery has provided all of the necessary documentation and both financial and operational assessments indicate this will be a positive project. The rate of cremation continues to climb throughout the state, and that will likely add to the success of this unit. For these reasons, I recommend approval of this application.

Exhibit A

DIVISION OF CEMETERIES

STATE OF NEW YORK
DEPARTMENT OF STATE
ONE COMMERCE PLAZA
99 WASHINGTON AVENUE
ALBANY, NY 12231-0001
TELEPHONE: (518) 474-6226
FAX: (518) 473-0876
WWW.DOS.NY.GOV

ANDREW M. CUOMO
GOVERNOR

CEMETERY BOARD

ROSSANA ROSADO
SECRETARY OF STATE
CHAIR

LETITIA JAMES
ATTORNEY GENERAL

DR. HOWARD A. ZUCKER
COMMISSIONER OF HEALTH

TO: New York Cemetery Board

FROM: Andrew Hickey, Senior Accountant

SUBJECT: Riverhurst Cemetery, Broome County, 04-027

DATE: December 22, 2020

SCHEDULES:

- 1) A Four-year Income and Expenses
- 2) A1 Four-year Balance Sheet and cost per acre
- 3) B1 Return on Investment and Project Costs

SUMMARY: The cemetery filed an application for the installation of a 96 double niche columbarium unit. This project would be their second columbarium unit. The Cemetery's initial unit, approved in 2019, is currently 40% sold and the trustees believe this second unit will promote additional columbarium sales as it provides another level of service compared to the initial unit. Cemetery trustees also believe the increase rate of cremation, as well as feedback from lot owners and the community requesting this type of burial option, show the importance of obtaining this second columbarium. The cemetery performs approximately 61 cremation burials a year (Schedule A). Trustees believe these figures will increase based on upward trend in cremations and planned marketing of the proposed columbarium. Cemetery columbarium marketing plans include radio advertisement, distribution of information packets to local funeral directors as well as utilizing print media and Cemetery's website.

Trustees indicated they received over \$13,000 in dedicated columbarium donations as of December 2020, and these funds are held in a separate savings account. Trustees feel this level of donations demonstrates the growing demand for this service, in addition to materially offsetting related acquisition costs.

Cemetery Trustees believe the approximate \$17,000 cost to purchase and install will be quickly recouped (trustees estimate 5-10 year timeframe) by niche sales and provide material positive cash flows for years to come. Trustees believe minimal (under \$250) expenses will be incurred to maintain the unit on an annual basis. Trustees established a preliminary \$2,200 charge per niche (ranging from \$2,000 - \$2,400 based on location). Trustees indicated the installation of the columbarium will not impact on traditional burial places as this 2nd columbarium will be located on land already dedicated for the initial columbarium approved by the Cemetery Board in 2019.

Riverhurst Cemetery is one of the larger cemeteries in Broome County and Trustees strongly believe the income generated from the sale of niches and future inurnments should improve the cemetery's long-term viability as well as providing an expanded service to the local community.

Background:

Although burial activity has remained constant, lot sales declined in 2019. The cemetery, on average over last four years, performed 79 full burials and 61 cremation burials. Trustees do not believe lot sales declines in 2019



Department
of State

are indicative of future results. Additionally, they believe this second columbarium and associated marketing will enhance future revenues.

Dividend and interest income provide substantial funding to the cemetery operations.

Average annual expenses per acre, of approximately \$11,000 (Schedule A), appear to be on the higher side of industry norms. Trustees asserted substantial efforts are being made to keep costs as low as possible. Trustees indicated the columbarium will not result, other than periodic cleaning, in additional annual operating expenditures.

Although asset levels (Sch. A1) have remained relatively constant, 2019 yearend asset levels decreased approximately \$130,000. This drop is largely a result of decreasing lot sales and investment losses. The cemetery's general funds, as of December 31, 2019, total \$202,174 and permanent maintenance funds total \$2,330,086. The Cemetery is current in all filings with the Division and there are no trust fund deficits. The Cemetery trustees adopted a conflict of interest policy. The Cemetery is consistently well-maintained.

FINANCING – RETURN ON INVESTMENT:

The columbarium project's estimated cost is \$26,120.00 (schedule B-1) and will be funded (**source of funds**) exclusively from the general fund (no external financing necessary). These general funds totaled \$ 202,174 as of December 31, 2019 (schedule A1) and the expense of the project will have only nominal impact on the financial levels of the Cemetery.

Based on Trustees' projections, the 96 niches will be all sold in five to 10 years. Although the current number of cremations performed would indicate a longer period to sell all 96 niches, the number of cremations will probably increase based on marketing of the Cemetery's new columbarium. The previous columbarium, approved in late 2018, is already 40% sold based on Trustees assertions. Even assuming the actual timeframe exceeds the estimated 5-10-year window to sell out, the very low cost of the project, estimated positive return on investment, increasing cremation burials trends, and planned marketing of columbarium should all help ensure a timely financial return on this investment. Furthermore, Trustees pointed out there should be good demand as there are very few cemeteries in this geographic area offering columbarium services.

The columbarium project has an estimated positive ROI of 750% ROI (schedule B1). Cumulative estimated revenues from sales and services total \$222,048 (assuming 90% realization). Costs to install, 10% PM allocation and marketing are estimated at \$26,120 and there is no reported cost of land as Trustees indicate no lots will be displaced.

Projected disposition of gross revenue: Permanent Maintenance allocation will be approximately \$21,120 (10% of total projected \$221,200 niche sales) and \$5,040 for approximate # of eventual inurnments (estimated at 144 of 192 @ \$35.00). Remaining disposition of revenue will go to general funds. There will be no allocation to other special funds. Marketing fees are estimated to be \$1,000 and included in the ROI calculation above.

RECOMMENDATION:

Based on information available to the Division Accountant and the most recent audit and the project application, the recommendation would be to approve the columbarium project.

| | | | | | |
|---|-------------------------------|-------------------|-------------------|-------------------|---------------------|
| Exhibit A | 4 Y/R Income Expense Analysis | | | | |
| Name | Riverhurst Cemetery | | | | |
| County | Broome | | | | |
| Cemetery # | 04-027 | | | | |
| Conclusions about revenue | | | | | |
| 1) Cemetery's lot and mausoleum sales were steady in 2016 and 2017 but appear to be decreasing in 2018 and 2019. The # of annual full burials is steady, but cremation burials decreased in 2019. | | | | | |
| 2) Dividend income is steady and is sufficient to cover a material amount of expenses. | | | | | |
| 3) Rental income and service contracts are steady and appear to help cover a material amount of operating expenses | | | | | |
| Conclusions about Expenditures and results from operations | | | | | |
| 1) Operating expenditures are steady at \$430K | | | | | |
| 2) Operating losses became steady in 2018 and 2019 and were largely a result of decreasing burial income and investment losses | | | | | |
| Features: | 2016 | 2017 | 2018 | 2019 | Four Yr Avg |
| Acres(total) | 37.94 | 37.94 | 37.94 | 37.94 | |
| Available land | 10.5 | 10.5 | 10.25 | 10.25 | |
| Burials Full | 85 | 76 | 76 | 80 | 79 |
| Burials Cremations | 66 | 57 | 70 | 52 | 61 |
| Lot Sales | \$ 49,523.00 | \$ 74,100.00 | \$ 77,250.00 | \$ 55,600.00 | \$64,118.25 |
| YEAR | 2016 | 2017 | 2018 | 2019 | Four Yr Avg |
| Operating Income | | | | | |
| Lot Sales | 49,523 | 74,100 | 77,250 | 55,600 | \$64,118.25 |
| Mausoleum | 91,000 | 91,725 | 72,007 | 45,302 | \$75,008.50 |
| Interments | 111,449 | 68,954 | 68,032 | 55,636 | \$76,017.75 |
| Foundations | 7,850 | 10,800 | 9,663 | 6,250 | \$8,640.75 |
| Merchandise | 57,167 | 56,892 | 40,925 | 41,536 | \$49,130.00 |
| Other | | 3,326 | 3,851 | 4,549 | \$2,931.50 |
| Special Projects | | 20,658 | 6,690 | | \$6,837.00 |
| Total Revenue | 316,989 | 326,455 | 278,418 | 208,873 | \$226,147.00 |
| Annual change in operating revenues | | 2.99% | -14.71% | -24.98% | |
| Cost of Revenue | 2016 | 2017 | 2018 | 2019 | |
| Crypts | 32,261 | 27,517 | 22,002 | 13,591 | |
| Markers | 0 | 36,103 | 24,542 | 23,123 | |
| Total Cost of Rev | 32,261 | 63,620 | 46,544 | 36,714 | |
| Net Revenues from Operations | 284,728 | 262,835 | 231,874 | 172,159 | |
| Other Income | 2016 | 2017 | 2018 | 2019 | Four Yr Avg |
| Dividend Income | 47,337 | 47,603 | 65,954 | 84,980 | \$61,468.50 |
| Donations | | 50 | 50 | | \$25.00 |
| Rental Income | 35,739 | 42,320 | 41,613 | 45,773 | \$41,361.25 |
| Service Contract Rev1 | 50,000 | 50,000 | 50,000 | 50,000 | \$50,000.00 |
| Service Contract Rev2 | | | 29,741 | 38,178 | \$16,979.75 |
| Total Other | 133,076 | 139,973 | 187,358 | 218,931 | \$169,834.50 |
| Total Revenue | \$ 417,804 | \$ 402,808 | \$ 419,232 | \$ 391,090 | \$407,733.50 |
| Other Changes in Assets | 2016 | 2017 | 2018 | 2019 | Four Yr Avg |
| Realized Gains | 9,410 | 5,824 | 10,230 | 12,087 | \$9,387.75 |
| Realized Gains/(losses) - Restricted | 19,274 | 39,191 | 205,369 | -104,358 | \$39,869.00 |

| | | | | | |
|---|---------------------|---------------------|----------------------|-----------------------|---------------------|
| Total other Changes in assets | 28,684 | 45,015 | 215,599 | -92,271 | \$49,256.75 |
| Total Revenues | 446,488 | 447,823 | 634,831 | 298,819 | \$456,990.25 |
| Expenses Operating and Maintenance | 2016 | 2017 | 2018 | 2019 | Four Yr Avg |
| Salaries and Wages | 145,582 | 85,062 | 106,266 | 119,091 | \$114,000.25 |
| Depreciation | | 22,573 | 5,237 | 16,653 | \$11,115.75 |
| Repairs and Maintenance | 2,164 | 3,172 | 8,933 | 15,600 | \$7,467.25 |
| Payroll Taxes | | 10,264 | 7,346 | 11,682 | \$7,323.00 |
| Real Estate Taxes | 13,212 | 13,643 | 13,714 | 13,751 | \$13,580.00 |
| Shop Materials | 11,230 | 1,943 | 4,667 | 6,224 | \$6,016.00 |
| Subcontractors | 38,961 | 55,971 | 37,298 | 36,692 | \$42,230.50 |
| Utilities | 7,165 | 6,596 | 7,825 | 8,145 | \$7,432.75 |
| Trees, Landscaping and ground keeping | | 1,622 | 4,211 | 2,232 | \$2,016.25 |
| Equipment | 11,230 | | | | \$2,807.50 |
| Total Expenses | 229,544 | 200,846 | 195,497 | 230,070 | \$213,989.25 |
| Administrative | 2016 | 2017 | 2018 | 2019 | Four Yr Avg |
| General and Admin Salaries | 67,500 | 65,210 | 69,812 | 80,165 | \$70,671.75 |
| Insurance | 47,151 | 27,435 | 26,876 | 35,289 | \$34,187.75 |
| Employer Retirement Expense | 4,697 | 600 | 1,673 | 1,537 | \$2,126.75 |
| Legal and Accounting | 14,453 | 10,518 | 13,673 | 10,988 | \$12,408.00 |
| Meals | 737 | 259 | 559 | 198 | \$438.25 |
| Director's Fees | 18,000 | 18,000 | 18,000 | 18,000 | \$18,000.00 |
| Payroll Taxes | 23,794 | 7,869 | 7,346 | 7,864 | \$11,718.25 |
| Gas and Oil Expense | 3,307 | 4,085 | 5,922 | 5,790 | \$4,776.00 |
| Surveying and Architect Fees | | 765 | 5,553 | | \$1,579.50 |
| Garage Expenses | 4,263 | 5,965 | 3,735 | | \$3,490.75 |
| Telephone | 3,925 | 3,848 | 6,557 | 7,284 | \$5,403.50 |
| Office Supplies | 6,030 | 5,096 | 3,308 | 2,567 | \$4,250.25 |
| Bank Service Charges | 6,264 | 2,532 | 2,919 | 2,137 | \$3,463.00 |
| Advertising | 8,104 | 5,963 | 3,529 | 5,178 | \$5,693.50 |
| Depreciation Expense | | 12,262 | 28,108 | 18,986 | \$14,839.00 |
| Commissions | | 30,008 | 32,780 | 0 | \$15,697.00 |
| Contributions | | 175 | | 50 | \$56.25 |
| Corp taxes | 250 | 250 | 250 | 250 | \$250.00 |
| Payroll Service | 2,572 | 2,684 | 2,857 | 3,058 | \$2,792.75 |
| Misc Expense | 2,019 | 2,357 | 553 | 110 | \$1,259.75 |
| Interest Expense | 4,113 | | | | \$1,028.25 |
| Permits | 939 | | | | \$234.75 |
| Dues | 257 | | 723 | 859 | \$459.75 |
| Total Expenses | 218,375 | 205,881 | 234,733 | 200,310 | \$214,824.75 |
| Total Expenses | 447,919 | 406,727 | 430,230 | 430,380 | \$428,814.00 |
| Total Surplus/(Deficit) | -\$ 1,431.00 | \$ 41,096.00 | \$ 204,601.00 | -\$ 131,561.00 | \$28,176.25 |
| Expense per acre | 11,806 | 10,720 | 11,340 | 11,344 | 11,302 |

| | |
|------------|---------------------|
| Exhibit A1 | 4 YR Balance Sheet |
| Name | Riverhurst Cemetery |
| County | Broome |
| Cemetery # | 04-027 |

Conclusion on Assets:

1) Cemetery financial assets have remained steady, but did decline in 2019, largely related to market losses and decreasing lot sales.

| Balance sheet- Financial Assets | 2016 | 2017 | 2018 | 2019 |
|---|--------------------|--------------------|--------------------|--------------------|
| General fund | \$321,007 | \$220,694 | \$233,296 | \$202,174 |
| Permanent Maintenance | \$2,049,993 | \$2,178,223 | \$2,398,423 | \$2,330,086 |
| Total Financial assets | \$2,371,000 | \$2,398,917 | \$2,631,719 | \$2,532,260 |
| Balance sheet- Non- Financial Assets | | | | |
| Cost of Unsold Crypts | \$475,007 | \$444,532 | \$422,930 | \$409,332 |
| Perpetual Care | | | | |
| Property, Plant, equipment net of Depr. | \$2,194,993 | \$2,128,118 | \$2,120,234 | \$2,099,095 |
| Total Non-financial asse | \$2,670,000 | \$2,572,650 | \$2,543,164 | \$2,508,427 |
| Total Assets | \$5,041,000 | \$4,971,567 | \$5,174,883 | \$5,040,687 |
| Balance sheet- Liabilities | 2016 | 2017 | 2018 | 2019 |
| Other liabilities | | \$8,282 | \$6,997 | \$4,812 |
| M&T Loan | \$290,667 | | \$0 | |
| Total liabilities | \$290,667 | \$8,282 | \$6,997 | \$4,812 |
| Assets net of liabilities | \$4,750,333 | \$4,963,285 | \$5,167,886 | \$5,035,875 |

| | | | |
|-------------|---------------------|--|--|
| Schedule B1 | Cost and ROI | | |
| Name | Riverhurst Cemetery | | |
| County | Broome | | |
| Cemetery # | 04-027 | | |

| COSTS to install | | Comments | |
|---|--------------|----------|--|
| Columbarium Unit | \$17,684.00 | | Per initial rate app |
| Other installation costs | \$0.00 | | Per 12/16/20 discussions with Lisa Klein |
| Foundation | \$0.00 | | Per 12/16/20 discussions with Lisa Klein |
| Permanent Maintenance allocation 10% | \$21,120.00 | | PM allocation 10% of selling price |
| Marketing, signage, print materials, etc | \$1,000.00 | | Per 12/16/20 discussions with Lisa Klein |
| Other- receipt of dedicated columbarium fundraising | -\$13,684.00 | | |
| Total planned/budgeted costs | | | \$26,120.00 |
| Cost per niche (64 niches) | | | \$435.33 |

| Planned Pricing Schedule | | | |
|---|------------|----------|---|
| Price per niche (double depth) | \$2,200.00 | | |
| Engraving fee - Initial | \$215.00 | | For first interment for 2nd, add dates, etc \$150 per X 2 |
| Less engraving cost | -\$215.00 | | |
| Est. Opening fee (per inurnment) (\$235-35) X 2 | \$400.00 | | Assumes two openings per niche @ \$315/ea |
| Less inurnment cost 2 hours @15 | -\$30.00 | | |
| Gross revenue per niche | \$2,570.00 | per unit | \$246,720.00 |
| Less: 10% | | | \$24,672.00 |
| 90% estimated realization | | | \$222,048.00 |
| Less total planned/budgeted costs | | | \$26,120.00 |
| Total anticipated net profit for the | | | |
| Anticipated return on columbarium | | | \$195,928.00 |

NOTE: Cost of Land
This columbarium unit will be located on land already allocated for the previous columbarium unit (2019) and therefore this is no "cost of land" for lost traditional burials 0.00

| | | |
|-----|---------|--------------|
| ROI | Revenue | \$222,048.00 |
| | Cost | \$26,120.00 |
| | ROI % | 750% |

Exhibit B

Riverhurst Memorial Association, Inc.



Serving Our Community Since 1911

December 1, 2020

Division of Cemeteries
99 Washington Ave.
Albany, NY 12231

Attention: Mr. Lewis Polishook

Dear Mr. Polishook,

It is the feeling of the Board of Directors of Riverhurst Cemetery, Town of Union, Endicott, New York, That with our present rate of sales due to increased interest in cremation and need for affordable space, Necessitates construction to begin upon approval from the Division of Cemeteries on Columbarium 2 (C2).

Therefore in compliance with Section 1401, Article 201.11, I have enclosed the following information.

Item 201.11

Board of Directors of Riverhurst Cemetery did approve the planning of Columbarium unit 2 at the Columbarium unit 1 meeting, Columbarium unit 2 was authorized by funds that were donated for this project. Authorizing us to spend up to \$17,684.00.

1. Contractor – Premier Columbaria 2309 S. Tacoma Way, Tacoma, WA 98409
2. Map of Project – C2 See drawings
3. Riverhurst has elected to fund C2 using donations received to purchase the second unit.
4. Maintenance funds required for year to year maintenance and long term preservation, yearly cleaning of crypt fronts, sidewalks. Cost is less than \$1,000.00 yearly.
5. Prices based on \$2,200.00 average price per double niche spaces at 96 spaces total. Estimated total revenue \$211,200.00/prices to be reviewed annually.
6. Outstanding certificates of indebtedness or land shares – not applicable
7. Disposition of total estimated sales
Permanent Maintenance Fund @ 10
Current Maintenance Fund @15%

\$211,200.00 Income
\$21,120.00 PM Fund
\$31,680.00 CM Fund
\$158,500.00 Balance

No Special Trust Funds

RECEIVED
DIV. OF CEMETERIES

ALBANY OFFICE
DEPARTMENT OF STATE

✓
Thomas
Brenlich
1st Approved
2/20/21

Construction Cost \$17,684.00

General Fund Retention \$140,816.00

Columbarium construction notices posted at entrance and at site as required. Brendon Stanton and Andrew Hickey notified...12/01/2020.

Mr. Polishook, thank you for your prompt attention in the past, and we anticipate your approval to proceed as soon as possible.

Sincerely,



Lisa Klein
Executive Director
Riverhurst Cemetery

Exhibit C

RIVERHURST MEMORIAL ASSOCIATION, INC.

BOARD OF DIRECTORS

Annual Meeting

Wednesday, February 3, 2021

The **110th Annual Meeting** of the Board of Directors was held at the Riverhurst offices at 2500 East Main Street, Endicott, NY 13760.

Joe Meagher, Chairman of the Board and President called the meeting to order at 10:20 AM.

Directors present were: Joseph B. Meagher,
R. Theodore Warner,
Greg Chianis,
Phil Struzzi,
Andrew Blight,
Roger A. Cooper,

Absent: none

Also present: Riverhurst Superintendent Lisa Klein,
Lot owners: Lester Todd, Christine Blight, Steve Rogers

1. A quorum of five lot owners was present.
2. A motion was made by Phil S and seconded by Roger C to appoint Joseph Meagher as President Pro tem, and R. Ted Warner as Secretary Pro tem for this annual meeting. Unanimously carried
3. A legal notice publicizing today's Annual Meeting was published in the Press & Sun Bulletin on January 13, 2021 and Jan 20, 2021 and Jan 27, 2021 which. A copy of the notice is attached to these minutes as ADDENDUM A.
4. A motion was made by Phil S and seconded by Ted W to dispense with the reading of the Annual Meeting minutes held on January, 2020. Unanimously carried.
5. A motion was made by Roger C, seconded by Ted W to nominate the following two people to the Riverhurst Board of Directors for three years beginning today through the Annual Meeting of January, 2024.
 - A. Joe Meagher
 - B. Phil Struzzi
 Unanimously carried.
8. Superintendent Report by Lisa Klein:
 - A. She reported that Superintendent Gary Bussom had resigned and retired in November, 2020.
 - B. She reported that she (Lisa Klein) was hired as the new Superintendent
 - C. She reported that the bronze feature of a woman with an umbrella walking in the rain with children had been slightly damaged and is now repaired.
 - D. She presented the **Annual Report for 2020** which is attached to these minutes as Addendum B.
 - E. The Sales Statistics Report for 2020 was not presented and is not included or attached as part of these minutes. This will be presented at the next board meeting

9. **Other Business** none

10. **Resolutions:**

A. A motion was made by Phil S and seconded by Roger C to approve the Annual Report. For 2020. Unanimously carried

B. A motion was made by // and seconded by // to approve the Sales Statistics Annual Report. for 2020. --- none ---

C. A motion was made by Phil S and seconded by Roger C to approve the purchase of a second columbarium. Unanimously carried.

11. **The meeting was adjourned** at 10:35 AM. Motion: Ted W Second: Andy B. Unanimously carried.

Respectfully submitted

R. Theodore Warner, Secretary

ADDENDUM A

Annual Meeting legal notice

... 20145, PIN 950121, FA
Proj 2001-9501-213,
Broome Co., Resurfacing I-
81, Town of Kirkwood, City
of Binghamton, Night Time
Work, Bid Deposit: 5% of
Bid (~ \$200,000.00), Goals:
DBE: 5.00%
1/6, 1/13/2021
0004533983-01

LEGAL NOTICE

The Annual Board Meeting of the members of Riverhurst Memorial Association, Inc. will be held via a telephone conference to be held on **Wednesday, February 3, 2021, at 10:00 a.m.**, local time, for the election of Directors and the transaction of such other business as may be properly brought before the meeting.

Due to the Novel Coronavirus (COVID-19) emergency, access to this meeting will be held via Zoom only. Lot owners may contact our office meeting information. 785-8118.
1/13, 1/20, 1/27/2021
0004549830-01

**FINDING WORK
SHOULDN'T BE WORK.**

POWERED BY
The Recruiter

ADDENDUM B

ANNUAL REPORT 2020

By Lisa Klein, Riverhurst Superintendent

2/3/2021

During 2020 in addition to the Annual Meeting and the Organizational Meeting there were 4 Regular meetings held by the Board of Directors, also several committee meetings were held by the Personnel, Finance, and Building & Development.

M & T Investment Reps attended our meeting to discuss investments at the November meeting.

We completed our financial audit as required by the State of NY.

NYS Insurance fund audit was completed satisfactorily for our Workman's Comp. A budget was submitted at the November 2020 meeting for review and approved.

Riverside Cemetery had 15 burials in addition to maintenance of the grounds.

Vestal Park had 27 burials in addition to maintenance of the grounds.

Completed NYS Cemetery audit with Mr. Andrew Hickey.

Posted approval for NYS Cemetery for installation of the 2nd columbarium.

Coming in the spring 2021, the new Ossuary, 1 sold preneed.

New Urn Garden and developing a Veteran's Lawn.

Gary Bussom retired, Lisa Klein hired.

Website has been updated, directional signs have been repaired.

Feature in new urn garden has been repaired.

New tenant in 308, 2 week down time.

In an effort to promote Riverhurst Cemetery, direct mailers will be sent out every other month in the 13760 zip code.

Attach the meeting's legal notice in the paper to these minutes as Addendum A

Attach last year's Annual Report to these minutes as Addendum B

Attach last year's Sales Statistics report to these minutes as Addendum C

Exhibit D

#3

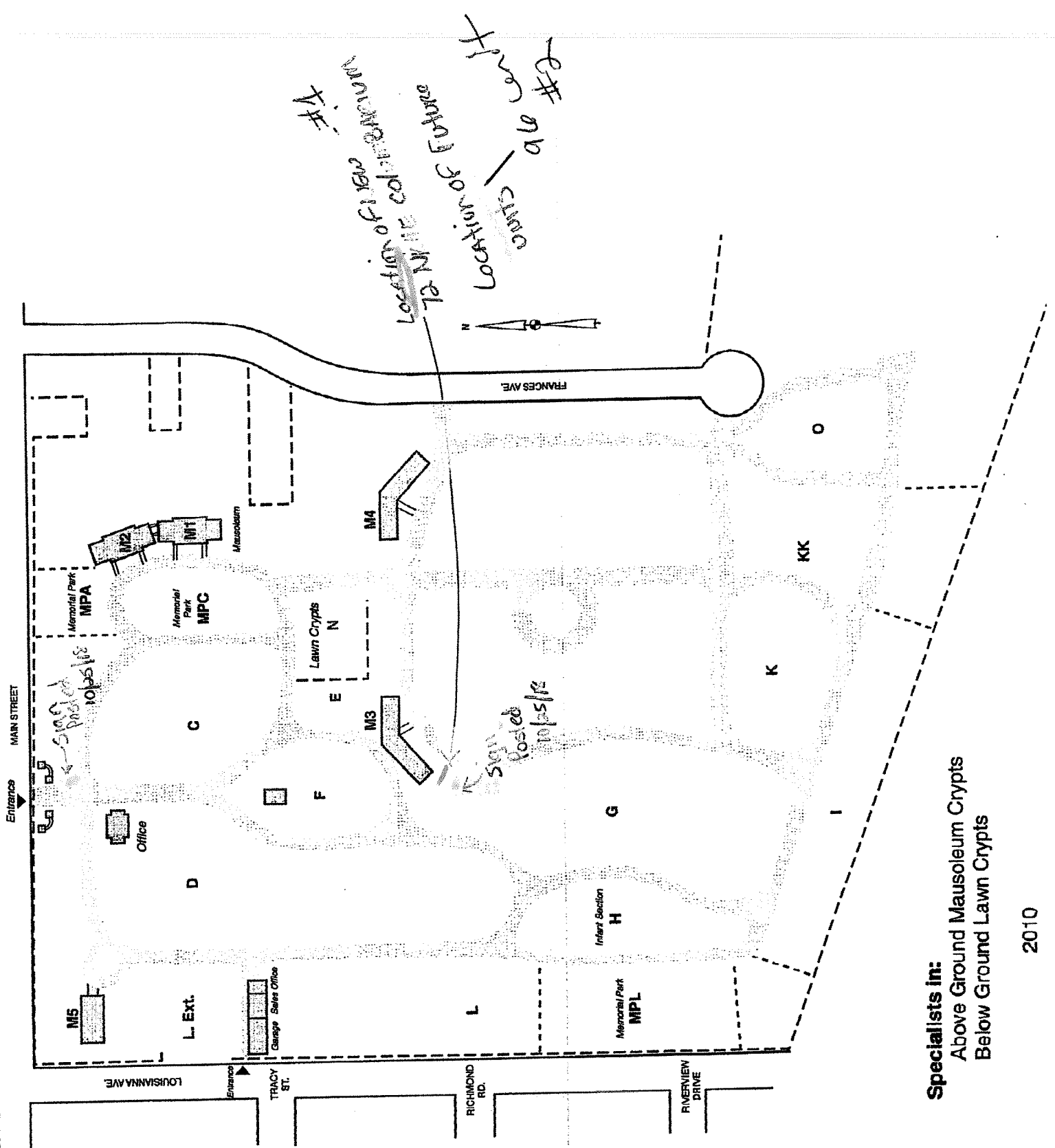

Specialists in:
 Above Ground Mausoleum Crypts
 Below Ground Lawn Crypts

2010



Search Google Maps



See travel times, traffic and nearby places



B

Louisiana Ave

Riverhurst Cemetery



2500



Map

Google



Exhibit E

- ① 84*84*3 1pc
- ② 84*84*5 1pc
- ③ 79 1/2*8 5/8*2 16pcs
- ④ 3*3*1/2 1pc
- ⑤ 14 1/8*13 1/8*1 1/2 70pcs
- ⑥ 14 1/8*12*3/4 96pcs
- ⑦ 79 1/2*15 1/2*1 1/2 8pcs
- ⑧ 79 1/2*15 1/2*2 8pcs

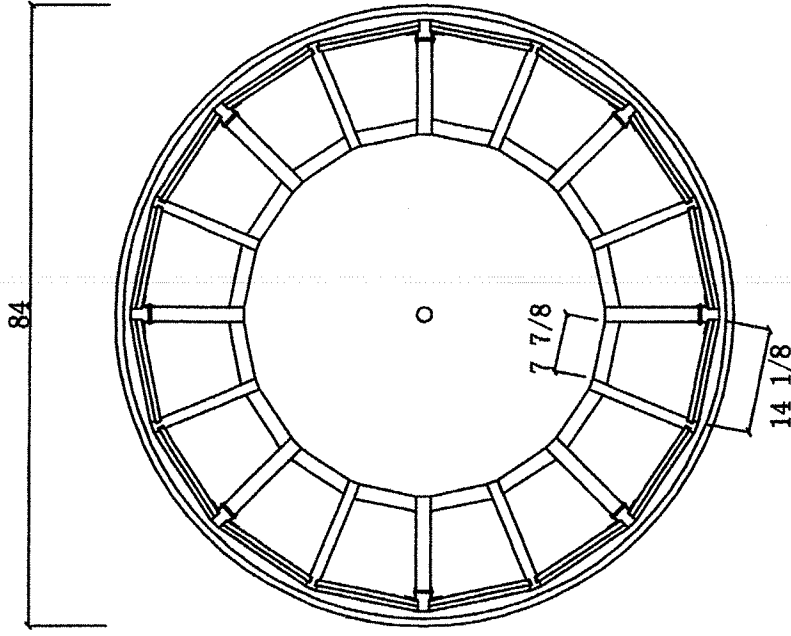
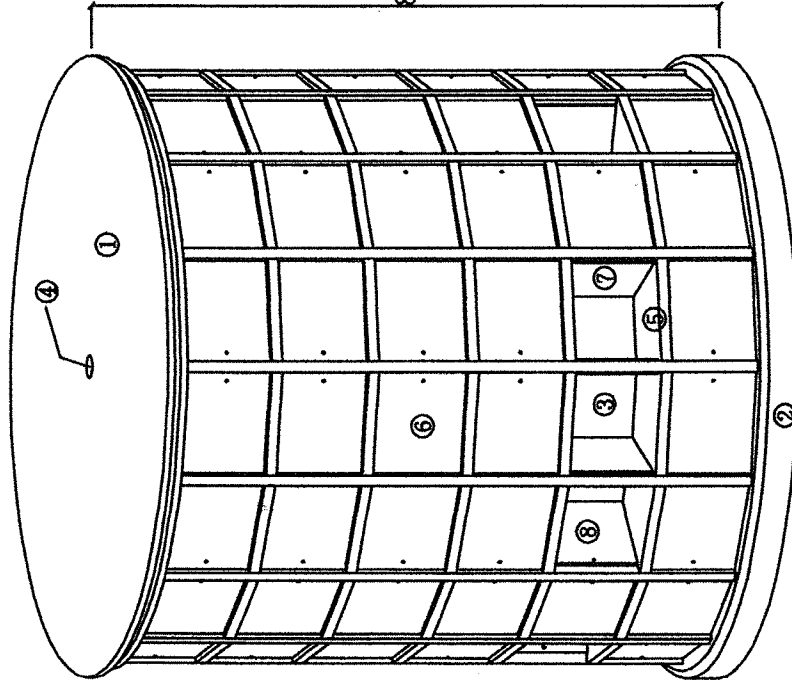

Premier Columbaria, LLC

Secure Slide Door™ with single rosette closure.

Copyright©2010 Premier Columbaria, LLC. All rights reserved.

DRAWING NO.

RKT-F-0117

SIZE

INCH (")

SHEET NO.

1 OF 4

SIGNATURE

DATE

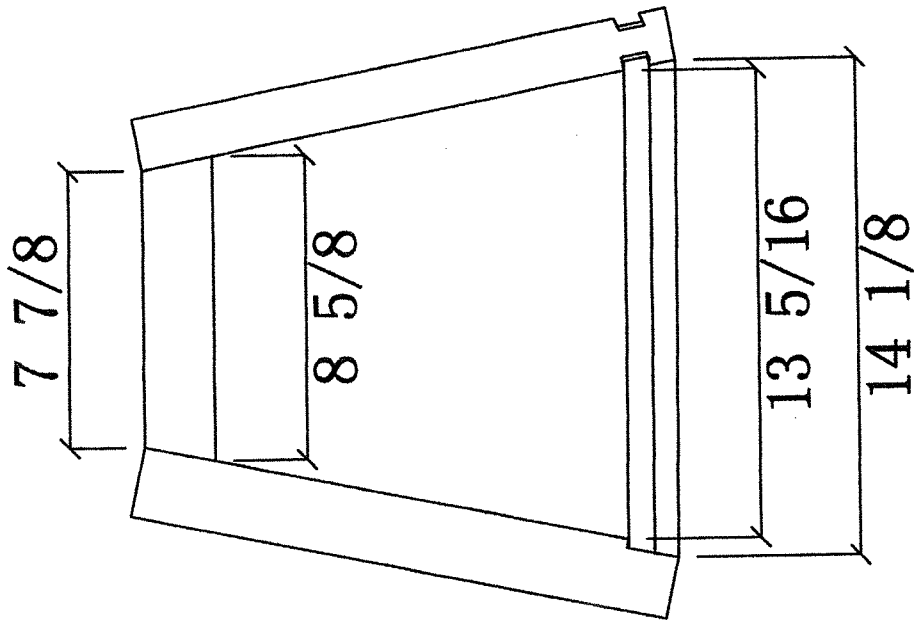

| | | | | | |
|--|--|---------------|--|-----------|--|
| Premier Columbaria | | Niche drawing | | Revision | |
| Secure Slide Door TM with single rosette closure Copyright 2020. | | Drawing Name | | Date | |
| Premier Columbaria LLC. All rights reserved. | | Drawing NO. | | 11-05 | |
| | | Units | | 2 OF 2 | |
| | | INCH (") | | Sheet NO. | |

Exhibit F



NEW

COLU^MBARIUM
(CREMATION SPACES)

CONSTRUCTION

COMMENTS BY 2/1/2021

DIVISION OF CEMETERIES
99 WASHINGTON AVE.
ALBANY, NY 12231

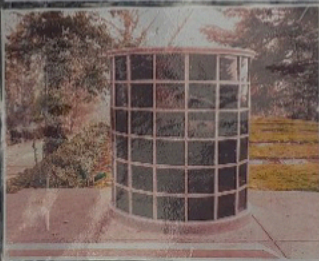

FOR AN APPOINTMENT
CALL OR STOP BY THE
OFFICE 607-785-8118



COLUMBARIUM
(CREMATION SPACES)

CONSTRUCTION

COMMENTS BY 2/1/2021

DIVISION OF CEMETERIES
99 WASHINGTON AVE.
ALBANY, NY 12231



FOR AN APPOINTMENT
CALL OR STOP BY THE
OFFICE 607-785-8118